



VALOR 4

4 BURNER BBQ

Model No. GM172-193



- Deluxe powder coated double skinned roasting hood
- 4 burners provide 50.4MJ/h total heat output (4 x 12.6MJ/h)
- Rust resistant powder coated body and hood
- LED illuminated control knobs
- Flush mounted stainless steel side sear burner
- Cast iron enamel hotplate and grills
- Cast iron burners with individual controls and enamel flame tamers to give even heat and reduce flare-ups
- Integrated rotary ignition
- Assembled dimensions (mm): 1450W x 1155H x 590D
- Total cooking area (mm): 720W x 450D
- Approved to NZ Standards

Important: Retain these instructions for future use.

GENERAL INFORMATION



IMPORTANT

Read these instruction carefully prior to use. Familiarise yourself with the appliance before connecting it to it's gas container. Keep these instructions for future reference.

Gas Installation Codes

- Barbecues must be used in accordance with New Zealand Standard 5601 "Gas Installations".
- Barbecues for use with bottled gas are labelled 'LPG/ULPG'.
- Barbecues for use with natural gas are labelled 'natural gas' and must be installed by an authorised person. Check the gas type sticker attached to the barbecue.

Clearances

Minimum Clearances from combustibile materials must be:
Rear - 1000mm Sides - 1000mm Above - 1000mm

Specifications

Barbecue specifications can be found on the data label attached to the door panel or the barbecue body.

Hose & Regulator Safety

The regulator and hose assembly supplied with the barbecue are suitable for LPG only.

A gas regulator adjusted to have an outlet pressure of 2.75kPa is supplied for connection to the LPG cylinder.

The pressure regulator and hose assembly supplied with the barbecue must be used. Replacement pressure regulators and hose assemblies must be those specified by the barbecue manufacturer.

When connecting the hose and regulator assembly to the gas cylinder, take care to avoid unnecessary twisting or kinking of the flexible hose.

After the assembly has been secured, turn on the gas and check for leaks by brushing a soap and water solution over all connections.

If you are unable to correct the leak by tightening the connections, turn off the gas and contact the supplier immediately.

Always ensure the barbecue is kept away from flammable materials and the gas cylinder clear of any heat source.

When changing over from an empty gas cylinder to a full one make sure this procedure is carried out in a flame free atmosphere.

When changing over from an empty gas cylinder to a full one make sure this procedure is carried out in a well ventilated location, preferably outside, away from people and away from any sources of ignition; such as naked flames, pilot flames, electric heaters/equipment.

Gas Cylinder Use & Safety

This is a low pressure barbecue and must only be used with the hose and regulator supplied. Your barbecue is designed for use with 9Kg LPG cylinders.

The gas cylinder should be filled by a reputable gas supplier and visually inspected and requalified at each filling.

Always keep cylinder in an upright position. Always close the cylinder valve when the barbecue is not in use.

Do not subject gas cylinder to excessive heat.

NEVER STORE YOUR GAS CYLINDER INDOORS.

If you store your barbecue indoors, ALWAYS disconnect the gas cylinder first and store the cylinder safely outside.

Cylinders must be stored outdoors in a well ventilated area out of reach of children, and must not be stored in a building, garage or any other enclosed area.



If you smell gas

1. Shut off gas to the barbecue at its source, if possible.
2. Extinguish any open flame.
3. Open hood.
4. If odour continues immediately call your gas supplier or fire department.

Nominal Hourly Gas Consumption

Gas Type	Number of BBQ Burners	Injector Size BBQ Burner	Injector Size Side Burner	Total Gas Consumption Primary Burners MJ/h	Gas Pressure kPa
ULPG	4	Ø .92mm	Ø .98mm	50.4	2.75 kPa
	MJ/h	12.6	14.4		

GENERAL INFORMATION



FOR YOUR SAFETY

Failure to comply with these instructions could result in a fire or explosion which could cause serious bodily injury, death or property damage.

CAUTION: Accessible parts may be very hot.

Keep young children away.

DO NOT modify this appliance.

DO NOT move this barbecue during use.

Turn off gas supply at the gas cylinder after use.

Parts sealed by the manufacturer or their agent must not be manipulated by the user. This barbecue is only to be used and stored outdoors.

- Never operate this barbecue without a regulator.
- Do not test for gas leaks with an open flame.
- If this information is not followed exactly a fire causing death or serious injury may occur. Do not store a spare gas cylinder under or near this barbecue. This barbecue is only to be used and stored outdoors.
- If there is a leak on your appliance (smell of gas) immediately attempt to turn off the cylinder valve. Remove the appliance to a well ventilated location away from any ignition source. Only check for leaks outdoors using soapy water. DO NOT try to detect leaks using a flame.
- Check for leaks by spraying a soapy water solution over all connections. If you are unable to correct the leak by tightening the connections, turn off the gas and contact customer service immediately.
- Only use the hose assembly as supplied with this appliance for connection to the cylinder - DO NOT USE ADAPTORS.
- After use, turn the appliance control knobs off, wait for the flame to go out then turn the gas cylinder valve off.
- Avoid twisting or kinking the flexible hose.
- Do not store or use petrol or other flammable liquids in the vicinity of this or any other appliance.
- Do not store empty or full spare gas cylinders under or near this or any other appliance.
- Never test for gas leaks with a lit match or open flame. Never light barbecue with hood closed or before checking to ensure the burner tubes are fully seated over gas valve orifices.
- Never lean over cooking surface when lighting.
- Never alter or modify the regulator or gas supply assembly.

- This barbecue must not be used indoors.
- Only use in well ventilated areas.
- CARBON MONOXIDE HAZARD - USING THIS APPLIANCE IN AN ENCLOSED SPACE MAY CAUSE DEATH. DO NOT USE IN CARAVANS, TENTS, MARINE CRAFT, CARS, MOBILE HOMES OR SIMILAR LOCATIONS.
- This appliance shall only be used in an above ground open-air situation with natural ventilation, without stagnant areas, where gas leakage and products of combustion are rapidly dispersed by wind and natural convection.
- Ensure the barbecue is set up on a level and stable surface.
- Do not move the barbecue while in use or when hot. Remove the drip tray before moving.
- DO NOT replace the grill with an extra hotplate. The warranty will be voided and it violates the gas approval, the grill provides the ventilation needed for the BBQ to operate safely. It is not designed to be a solid hotplate device.

IF THERE IS A LEAK

- Turn the cylinder off.
- Ventilate the area to disperse gas.
- Check all connections.
- If leak persists, keep the cylinder upright. Keep skin away from any gas or liquid escaping from the cylinder.
- Keep the cylinder at least 20 metres away from any sparks or ignition sources, including electrical equipment, camera flashes, engines and motors.
- Disperse gas by encouraging maximum ventilation and spraying with a fine water spray.

IF THERE IS A FIRE

- If the fire is at the barbecue, turn the gas off at the cylinder. Smother the flames with a wet cloth, fire blanket or extinguish using a fire extinguisher.
- If the fire is at the cylinder, or you can not get to the valve to turn the gas off, contact the fire brigade immediately.
- Using a garden hose, direct the water to the middle of the cylinder to keep it cool. Try not to extinguish the flame. At least if the gas is burning, it won't be able to build up pressure and explode.

GENERAL INFORMATION

Location of your Barbecue

DO NOT use your barbecue in garages, porches, breezeways, sheds or other enclosed areas. Your barbecue is to be used OUTDOORS. The barbecue is not intended to be installed in or on recreational vehicles and/or boats and should not be placed under any surface that will burn. Do not obstruct the flow of combustion and ventilation air around the barbecue housing.

Protect Children

Keep children away from barbecue during use and until barbecue has cooled after you have finished. Do not allow children to operate barbecue.

Always ensure that no sporting or physical activities are carried out in close proximity to the barbecue during use and while still hot.

General Assembly

Remove the barbecue and components from the packing carton. Check against parts list and lay components out within easy reach. Do not throw the carton away, unfold flat and use as a protective work surface. Contact your supplier for replacement parts if necessary.

PARTS LIST

No.	Description	QTY
1	Lid assembly	1
2	Thermometer	1
3	Thermometer bezel	1
4	Lid handle	1
5	Warming rack	1
6	Rear lid panel	1
7	Rear lid left side panel	1
8	Rear lid right side panel	1
9	Rubber buffer	5
10	Firebox	1
11	Side shelf bracket A	1
12	Side shelf bracket B	1
13	Control panel assembly	1
14	Knob bezel	5
15	Knob	5
16	Switch	1
17	Manifold assembly	1
18	Beam	1
19	Trolley rear panel	1
20	Door stopper	1
21	Trolley front lower panel	1

No.	Description	QTY
22	Wheel cover panel	2
23	Bottom shelf	1
24	Right door assembly	1
25	Left door assembly	1
26	Door handle	2
27	Hot plate	1
28	Cooking grill	2
29	Flame tamer	3
30	Cross fire	3
31	Burner	4
32	Burner ignition	4
33	Left side shelf	1
34	Side table panel	2
35	Side burner lid	1
36	Side burner lid axle	1
37	Side burner grill	1
38	Side burner	1
39	Side burner ignition	1
40	Side burner shelf	1
41	Side burner valve	1
42	Side burner fat cup	1

No.	Description	QTY
43	Drip tray handle	2
44	Drip tray	1
45	Fat cup	1
46	Hose & Regulator Assembly	1
47	Left rear leg	1
48	Trolley left side panel	1
49	Left front leg	1
50	Left end cap	2
51	Door handle screw sleeve	4
52	Right rear leg	1
53	Trolley right side panel	1
54	Right front leg	1
55	Wheel axle	2
56	Wheel	2
57	Battery case	1
58	LED light cord	1
59	LED light	5
60	Cylinder heat shield	1
61	Side burner housing	1
62	Side burner flexible hose	1
63	Cylinder belt	1

ASSEMBLY INSTRUCTIONS

Before assembling the barbecue, read these Instructions carefully.

Assemble the barbecue on a flat, clean surface.

The barbecue is heavy.

NOTE: Do not fully tighten all the nuts during the initial stages of assembly.

Caution: Sheet metal can cause injury. Wear gloves when assembling the barbecue.







Tools You Will Need

Standard Phillips-head screw driver (or cordless drill and bits), an Adjustable spanner and scissors.

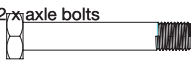
Check Barbecue for any Damage

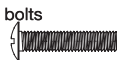
Inspect barbecue parts as you proceed. Contact your supplier for assistance regarding replacement of any damaged or missing parts. Do not assemble or operate a barbecue that appears damaged. Barbecues for use with gas cylinders are labelled 'LPG/ULPG'. Check labelling at the gas connection on your barbecue.

HARDWARE

A - 2 x axle bolts 	B - 2 x M8 nuts 	C - 4 x M6x30 bolts 	D - 4 x M6x15 bolts 
E - 48 x M6x12 bolts 	F - 4 x 	G - 4 x M6x15 bolts 	

EXPLODED DIAGRAM

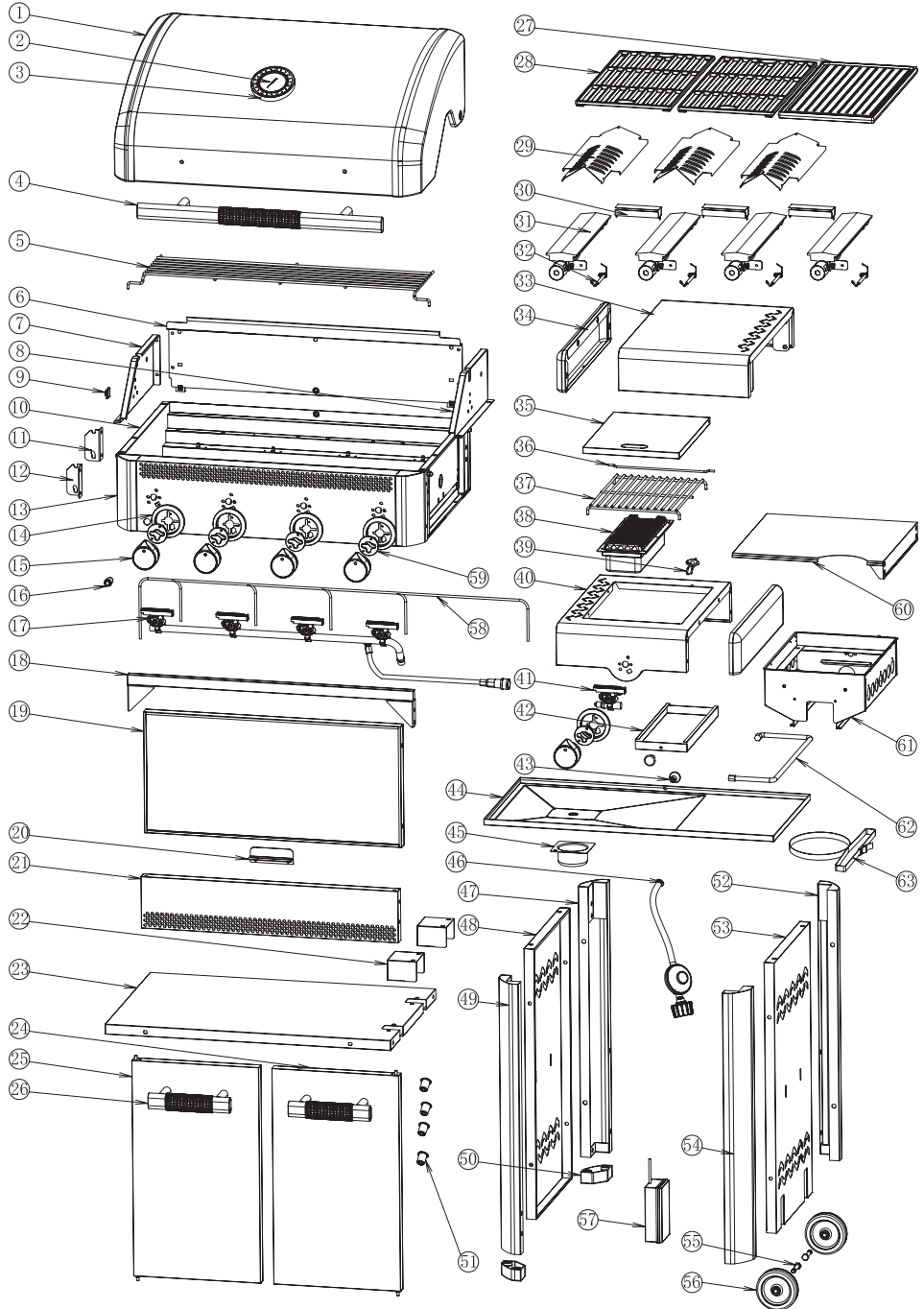

ASSEMBLY INSTRUCTIONS

STEP 1

Attach the trolley right side panel to right front leg and right rear leg with 4 x M6x12 bolts (E) as shown below. Attach the wheels to trolley right side panel with 2 x Axle bolts (A) and M8 nuts (B) as shown below.

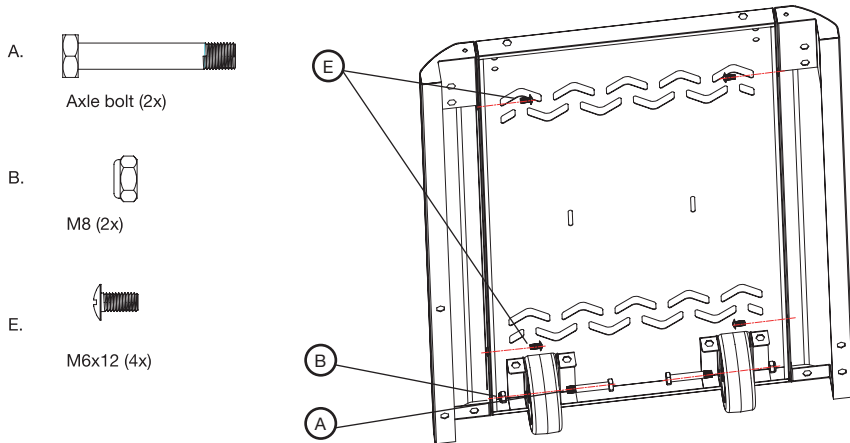

STEP 2

Attach the wheel cover panel to trolley right side panel with 4 x M6x12 bolts (E) as shown below.

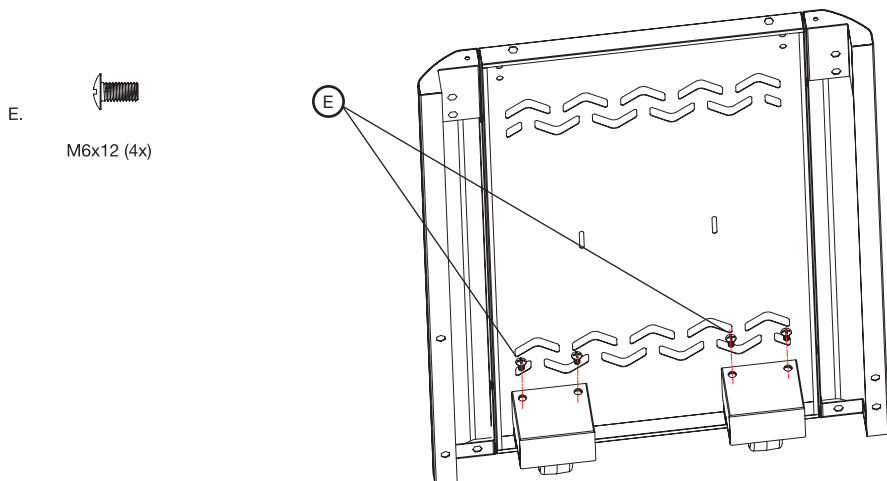

ASSEMBLY INSTRUCTIONS

STEP 3

Attach the trolley left side panel to left front leg and left rear leg with 4 x M6x12 bolts (E) as shown below.

Note: DO NOT tighten the screws of this step now.

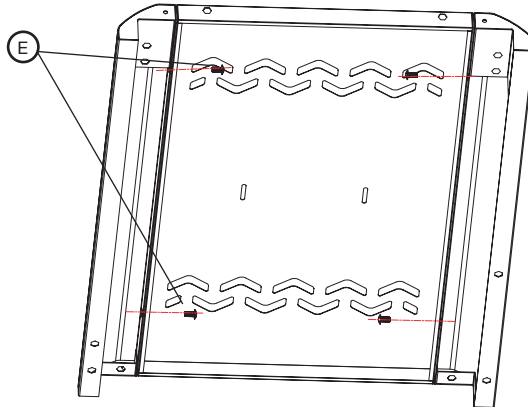
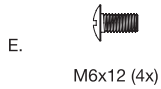

STEP 4

Attach the trolley front lower panel to front legs with 4 x M6x12 bolts (E). Attach the beam to front legs with 4 x M6x12 bolts (E) as shown below.

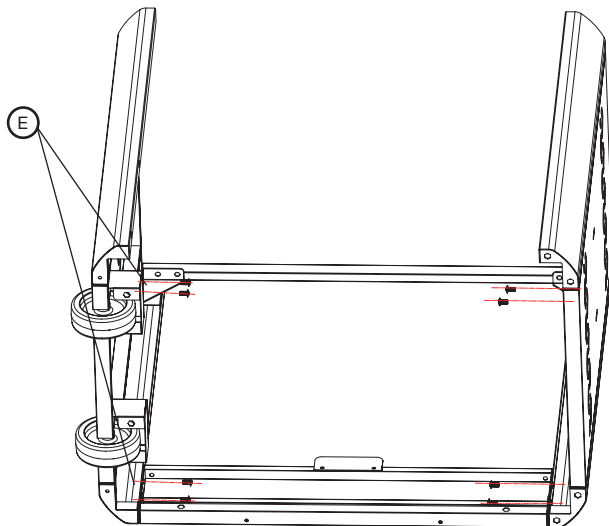
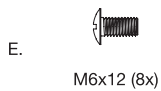

ASSEMBLY INSTRUCTIONS

STEP 5

Attach the bottom shelf to the legs with 4 x M6x12 bolts (E). Attach the bottom shelf to the wheel cover panel with 4 x M6x12 bolts (E). Attach the trolley front panel to the bottom shelf with 2 x M6x12 bolts as shown below:

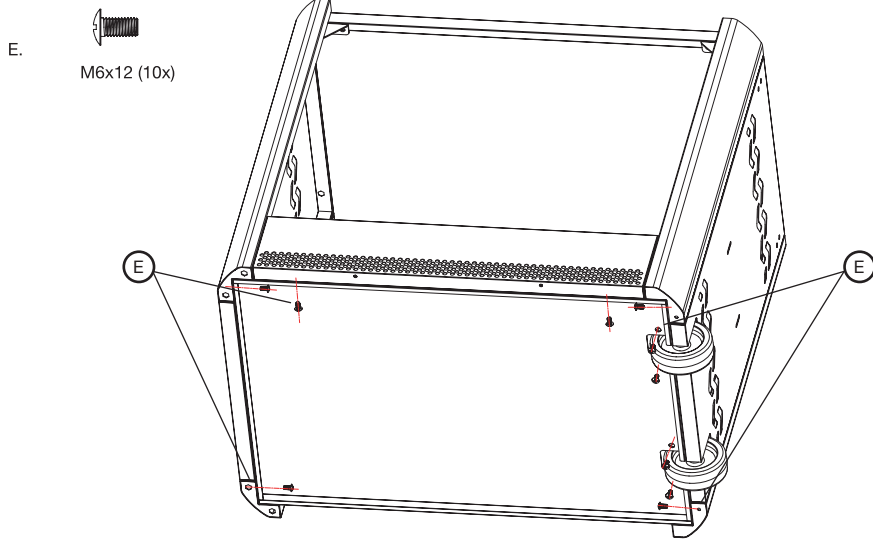

STEP 6

Attach the leg end cap to the left legs with 4 x M6x30 bolts (C) as shown below.

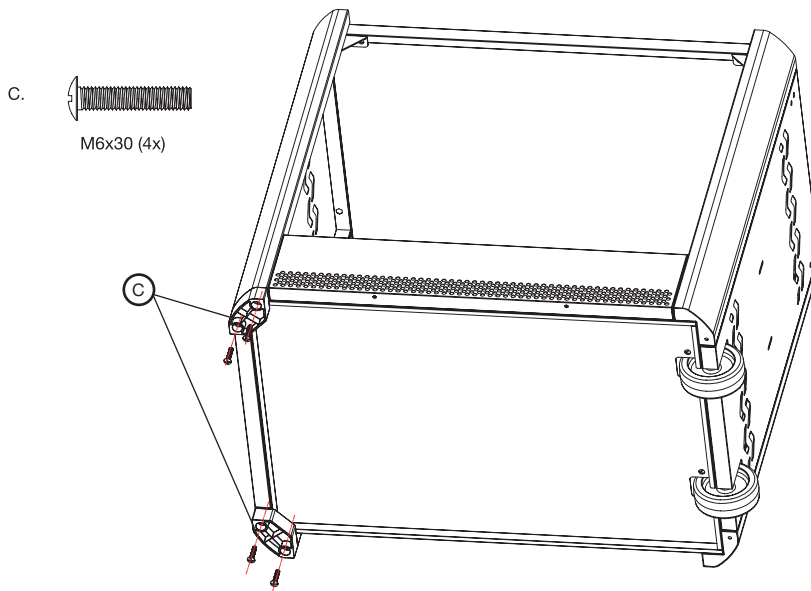

ASSEMBLY INSTRUCTIONS

STEP 7

Attach the trolley rear panel to the rear legs with 4 x M6x12 bolts (E).

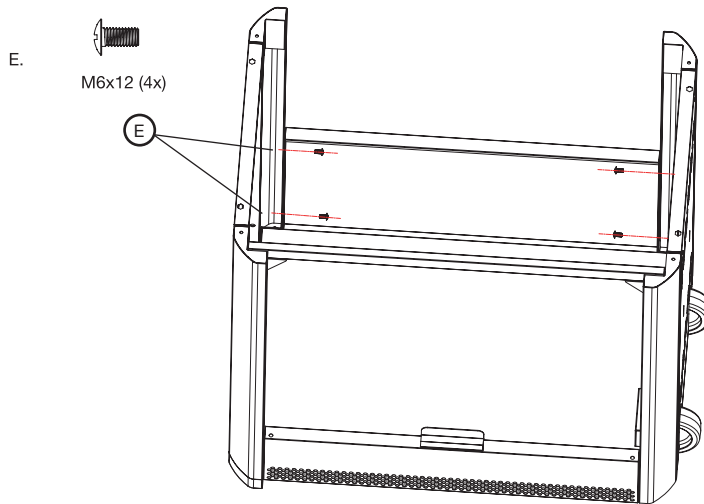

STEP 8

Attach the cylinder heat shield to trolley right side panel with 4 x M6x12 bolts (E).

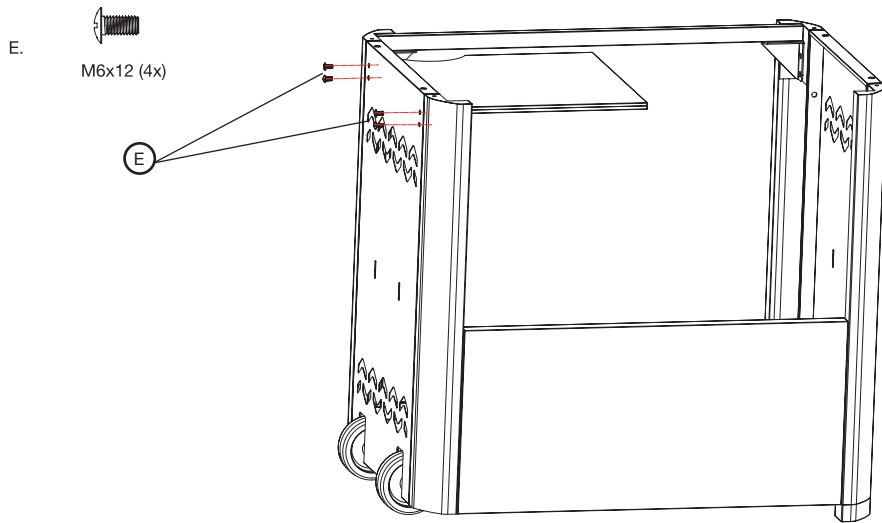

ASSEMBLY INSTRUCTIONS

STEP 9

Attach the firebox to the trolley side panels with 4 x M6x12 bolts (E).

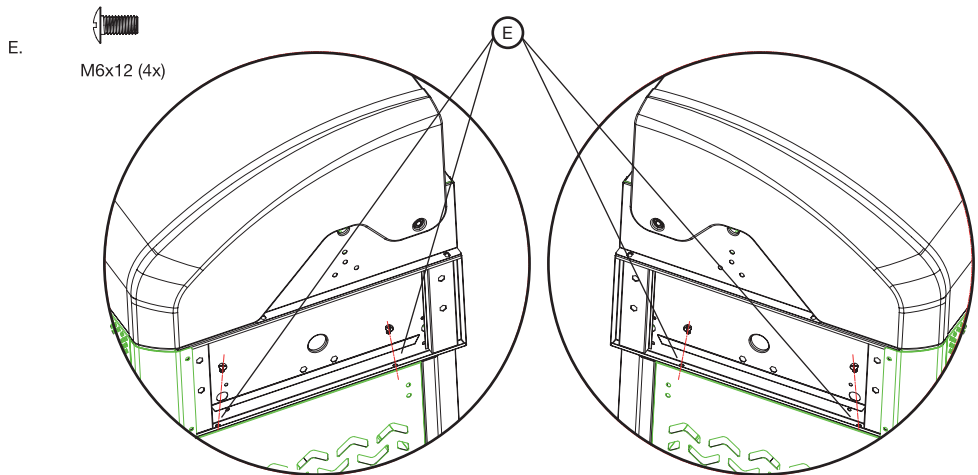

STEP 10

Attach the door handle to door with 2 x M6x12 bolts (E) and 2 x screw sleeves as shown below. Repeat with second door. Attach the cabinet doors.

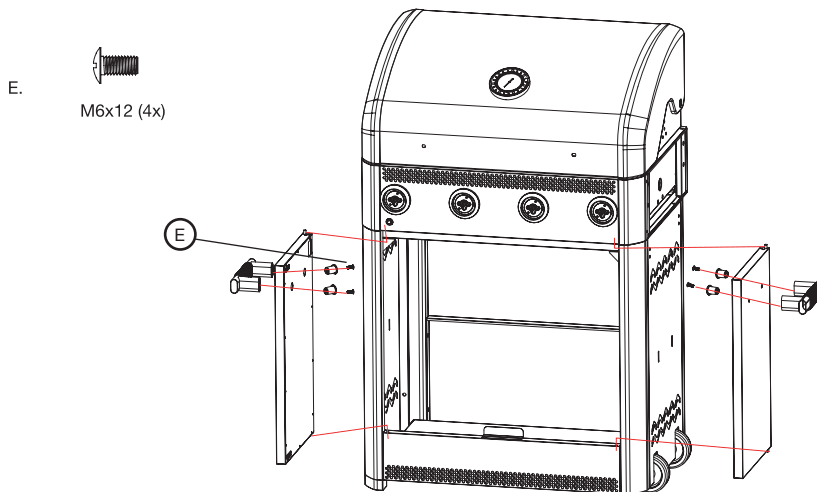

ASSEMBLY INSTRUCTIONS

STEP 11

Attach the lid handle to the lid with 2 x M6x12 bolts (E). Open the lid and put three flame tamers into the grill housing. Place the cooking grills and hot plate and warming rack in the grill housing as shown below. Ensure the grills are installed above the flame tamers. Attach the control knobs. Put batteries into the battery case.

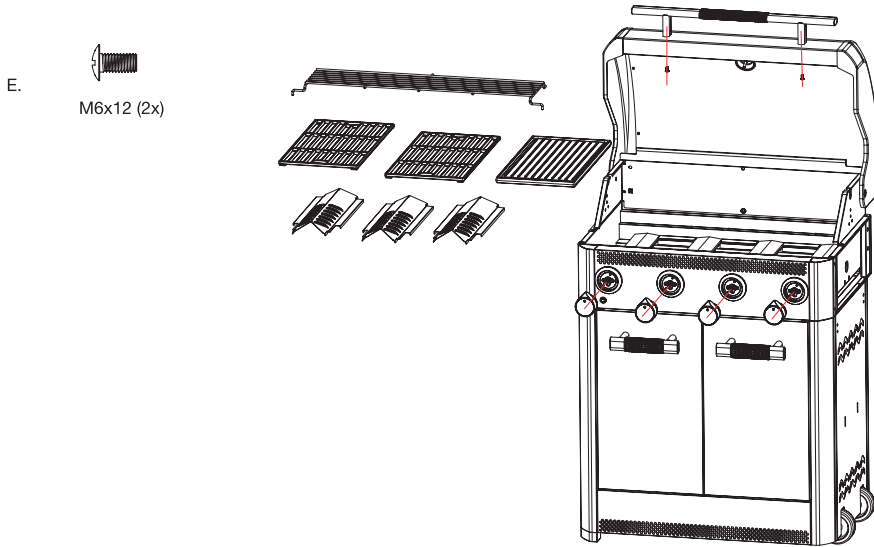

STEP 12

Attach the left side table bracket to firebox with 4 x M6x15 bolts (D). Then attach the left side shelf to shelf bracket with 4 x bolts (F) as shown below.

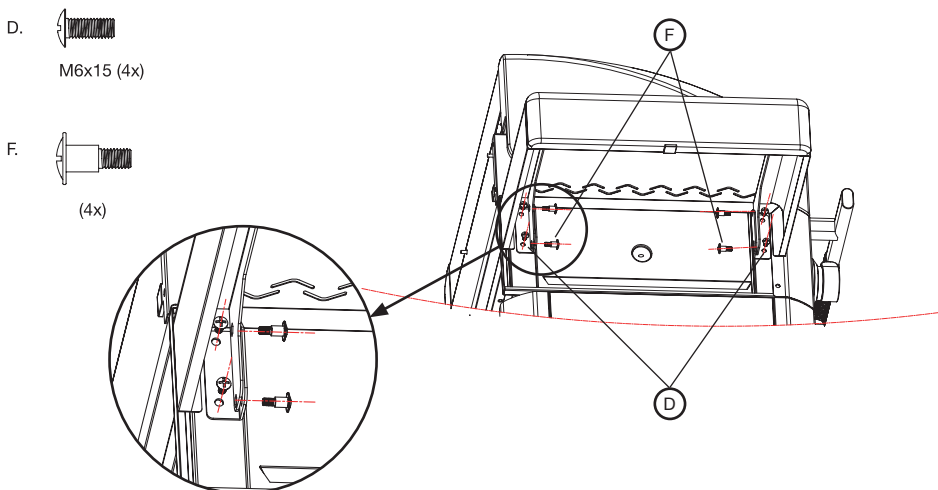

ASSEMBLY INSTRUCTIONS

STEP 13

Attach the side burner shelf assembly to right side of firebox with 4 x M6x15 bolts (G) as shown below.

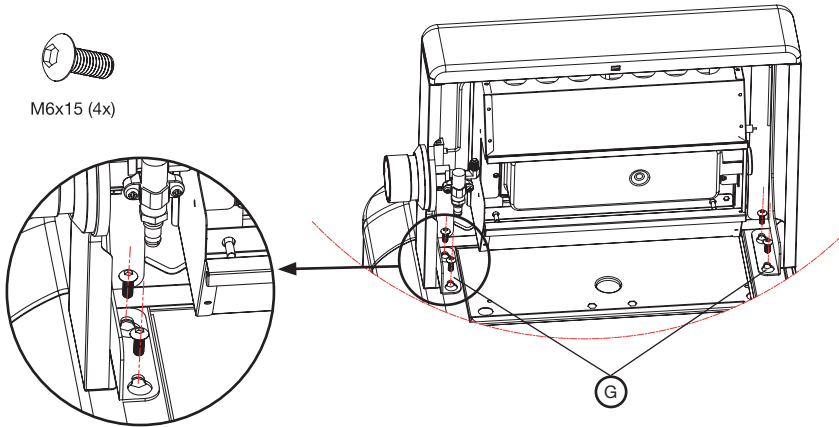
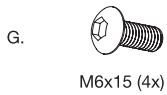

STEP 14

Attach the quick connector to side burner valve as shown below.

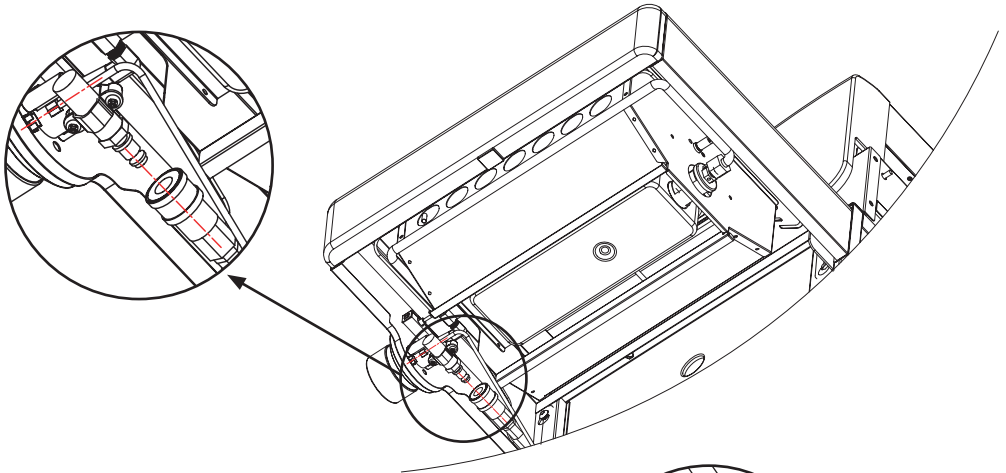

STEP 15

Attach the hose and regulator to the manifold connection.

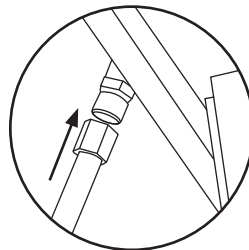

ASSEMBLY INSTRUCTIONS

STEP 16

Position 9kg gas cylinder into the BBQ trolley and attach the regulator to your gas cylinder.

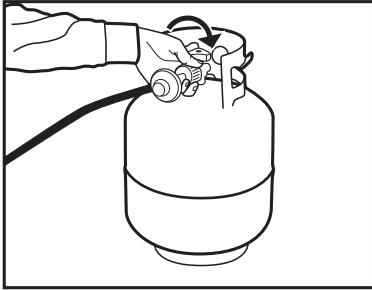

STEP 17

Turn on the gas cylinder ensuring that all of the controls on the BBQ are turned OFF at this point. DO NOT ATTEMPT TO LIGHT THE BBQ.

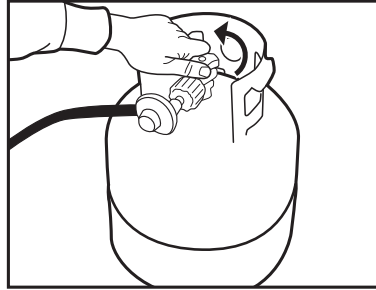

STEP 18

Use a solution of soapy water (dishwashing liquid and water is fine). Brush it on or use a spray bottle as shown in the drawing. Ensure the connections have a good coating.

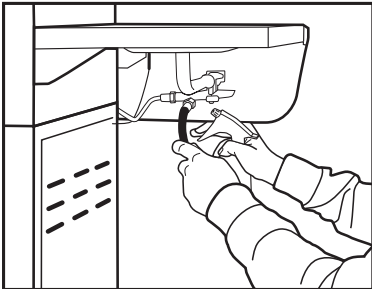

STEP 19

If the connection is leaking, bubbles will start to grow in the soapy solution. If this happens shut off the gas supply at the cylinder.

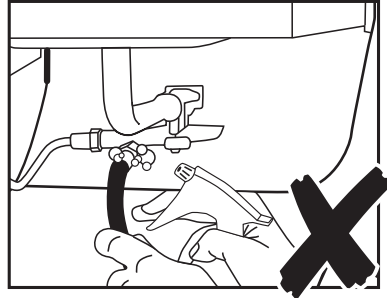

STEP 20

Tighten the connections using a crescent then repeat steps 18-19.

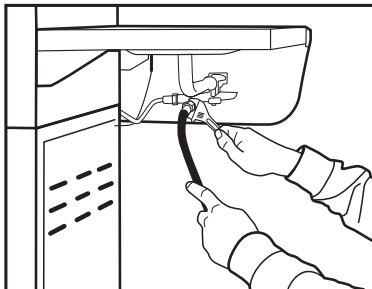

STEP 21

The connection is gas tight when no bubbles grow around the gas connection.

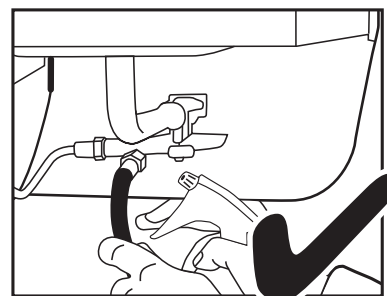

ASSEMBLY INSTRUCTIONS

STEP 22

Insert the drip tray from the back side of the BBQ, then store the fat cup on the brackets which are underneath the drip tray. Secure the gas cylinder with the cylinder belt.

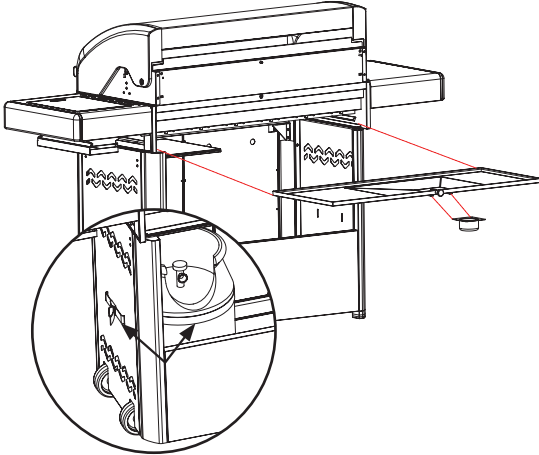

GENERAL ASSEMBLY

Connecting & Disconnecting to Gas Source



IMPORTANT:

- **IMPORTANT:** Before connecting and disconnecting barbecue to gas source, make sure burner controls are in 'OFF' position.
- **CAUTION:** When the barbecue is not in use, the gas must be turned off at the cylinder.
- Check that the seals between the appliance and the gas cylinder are in place and in good condition before connecting the gas cylinder.
- Do not use this appliance if it has damaged or worn seals.
- Check performance of burner prior to installing BBQ plates.

Familiarise yourself with the general information and safety guidelines located at the front of this manual.

Check:

1. The cylinder is filled. A sloshing sound will be heard when shaken.
2. The burner controls are in the 'OFF' position.

Connecting

1. Ensure cylinder valve is in its full off position.
2. Check for any damage to either the cylinder connection or the hose. NEVER attempt to use damaged equipment.
3. When connecting the hose to the cylinder tighten the nut to a positive stop by hand.
4. Open cylinder valve fully. If a leak can be heard at either end of the hose turn cylinder off and tighten joint. Wait 5 minutes before re-testing and use a soapy water solution to check the joint. If bubbles appear the connection will need to be re-tightened.

Refer to P13 for more detailed instructions on connecting the appliance to the cylinder.

Disconnecting

1. Ensure the burner control is in the 'OFF' position.
2. Ensure cylinder valve is in the full off position.
For storage and cylinder exchange, disconnect hose at the cylinder only, DO NOT disconnect hose from appliance.

Regulator Safety Feature

All QCC regulators (the part that attaches to the gas cylinder to regulate the flow of gas) have a safety feature included that restricts gas flow in the event of a gas leak. You can inadvertently activate this safety feature without having a gas leak. This typically occurs when you turn on the gas using the barbecue control knob before you turn on the gas cylinder valve. If the gas regulator safety feature activates, the barbecue will operate with reduced output as gas flow is restricted.

These steps should be taken first to reset the gas regulator safety device:

1. Ensure the barbecue hood is open.
2. Turn gas cylinder valve off.
3. Turn off all control knobs.
4. Disconnect the regulator from the gas cylinder.
5. Wait 30 seconds.
6. Reconnect the regulator to the gas cylinder.
7. Leak test the connection using a soapy water solution. Ensure no bubbles appear before proceeding.
8. Slowly open the gas cylinder valve all the way. Do not put excessive force on the valve at the full open position, to avoid damaging the valve.
9. Light barbecue as per the instructions provided.

LIGHTING PROCEDURE

Before lighting your barbecue for the first time, read the instructions fully to ensure the barbecue is assembled correctly and is ready for use.

Control Knobs

Each tube burner is controlled by a control knob. Each control knob has a bar to show its setting. Once a burner is lit, the temperature can be set as required by setting the control knob between HIGH / high temperature and LOW / low temperature.

Push in the button  to the left of the control knobs to switch on their LED background light. Push the button again to switch off the light.

Burner Operation & Ignition System Check

1. Open the hood of the barbecue before attempting to light the burners.
2. Turn all the control knobs clockwise to "OFF" position.
3. With cylinder valve in "OFF" position turn a control knob anti-clockwise to "HIGH" (a single click is heard). Check for sparking to the burner.
4. If spark is not evident at the burner ignition point, check that the ignition lead is firmly attached to the control and sparker tip.
5. With sparking established turn the cylinder valve 'ON'.
6. Push down and turn the control knob anti-clockwise to "HIGH" again. This will light the burner. Observe if the burner has lit. If not, repeat this process.
7. If the burner fails to ignite after several attempts turn off gas supply at cylinder valve and the control knob off (clockwise). Wait five minutes before attempting to relight with ignition sequence.
8. Following successful ignition, light the remaining burners in sequence, turn control knobs anti-clockwise to 'HIGH' starting with the burner closest to the ignition burner.
9. Adjust the heat by turning each control knob to the "HIGH"/"LOW" position.
10. To turn the barbecue 'OFF' turn the cylinder valve to the 'OFF' position, then turn the control knobs on the barbecue clockwise to the 'OFF' position.

If re-ignition is necessary while the gas barbecue is still hot, you must wait for a minimum of 5 minutes before commencing to re-ignite (this allows accumulated gas fumes to clear).



IMPORTANT:

- NOTE: If for some reason, ignitor fails to produce a spark at the electrode, BBQ can be lit by a long BBQ match. With hood open insert ignited match into burner lighting hole positioned on the right hand side of the BBQ body (underneath side shelf). Push and turn the far right control knob to HIGH. Burner ignition can be checked through this hole. Subsequent burners will cross light.
- Do not smoke when attempting to ignite BBQ.
- Never use volcanic rock, heat beads or other material.
- Always use protective gloves when handling hot components.

Side Burner

1. Lift up the hood or side burner cover (ensure it is always open when the burner is alight).
2. Push and turn the control knob anti-clockwise to HIGH (a single click is heard). This will light the burner. Observe if the burner has lit. If not, repeat this process.
3. If the burner fails to light after several attempts turn the control knob to 'OFF' and wait a few minutes before attempting re-ignition.



IMPORTANT:

The side burner is designed for use with a wok or cooking pot up to 220mm in diameter.

Use of larger pots may result in discolouration of the finish.

The hood must be in the open position for lighting.

Do not smoke at any time when attempting to ignite the barbecue burners.

Do not leave the barbecue unattended when alight.

Important: Never use all burners on high at the same time when cooking with the hood down.

BURNER OPERATION & IGNITION SYSTEM CHECK

Problem	Possible Reason	Solution
Burner will not ignite	Valve on cylinder is closed	Open the valve on the cylinder
	Control knob is closed	Push in and turn the knob anti-clockwise
	Electronic igniter is faulty	Use a long barbecue match (see page 15)
Food is not cooking or is taking too long	Burner has gone out	Check that the gas bottle is not empty and re-ignite the burner
	Cooking surface was not given enough time to warm up before the food was applied	Remove the food and give the burner time to warm the cooking surface (5-10 minutes)
	There is too much food on the cooking surface	Cook smaller portions
Flames on the burners burn in yellow or orange flames combined with the smell of gas	The inlets are obstructed	Check for spiders and insects or other obstructions. Clean the burner assembly (see page 18)
	Air shutter on the burner is not adjusted correctly	Adjust the air shutter correctly (see page 18)
	There is a gas leak	Perform a leak test (see page 13)
Flame is low while control knob is on high temperature setting or burner does not ignite	Check if the gas cylinder is empty	Install a full gas cylinder and check for leaks
	Check if the gas hose is bent or kinked	Straighten the gas hose
	The Excess Flow device has been activated. If the LPG cylinder valve is opened to allow gas flow while a burner control valve is already open, the surge of pressure will cause the device to activate	Make sure all burners are set to 'Off' before opening LPG cylinder. Wait 5 seconds after opening LPG valve. Light burners one at a time
When using the igniter function, the burner does not ignite	Check if gas flows out by following the manual lighting instructions	If the burner lights up, check if the igniter is working properly. If the burner does not light up, clean the burner assembly (see page 18)
	Check if the electrodes and ignitor cables are properly connected to the tube burners.	Install the electrodes properly to the tube burners and check if all ignitor cables are installed correctly
	Check if the electrodes are covered by cooking residue	Clean the burners as described in cleaning and care. Additionally clean the electrode tip with alcohol
Flame pattern on the burners is inhomogeneous or does not run the whole length of the tube burner	Check if the burners are clean	Clean the burners as described in cleaning and care
LED light of the knobs can't be switched on	Check connection and batteries	Replace the 3 x D batteries if necessary.
Burner blows out	Burner isn't installed properly	Check all parts are aligned correctly
	Fuel mixture	Close the gap on the adjustable air shutter
	Gas supply is insufficient	Straighten the gas hose and check that the gas bottle is not empty

Note: If the appliance cannot be adjusted to perform correctly it should not be used until serviced or repaired.

OPERATING PROCEDURE

Burn Off Cooking Surfaces

We recommend operating your barbecue on its highest setting for 15-20 minutes prior to first use. This aids removing the oils used during manufacturing. Allow the cooking surface to cool then we recommend seasoning it before use. Season your cooking surface by coating lightly with vegetable oil and bringing slowly up to a high temperature (do not use olive oil as this burns off at a low temperature). For best use your cooking surface should be seasoned two or three times throughout each barbecue season.

Preheating

It is necessary to preheat the barbecue for at least 5 minutes before cooking certain foods, depending on the type of food and the cooking temperature. Food that requires a low cooking temperature, needs only a period of 2-3 minutes preheating.

Cooking Temperatures

'HIGH' setting - Use this setting only for fast warm up, for searing steaks and chops, and for burning food residue from the grill plates after cooking is over. Rarely, if ever, do you use the 'HIGH' setting for extended cooking.

'MEDIUM' setting (mid-way between 'HIGH' and 'LOW'). Use this setting for most grilling, and for cooking hamburgers and vegetables.

'LOW' setting - Use this setting when cooking very lean cuts such as fish.

These temperatures vary with outside temperature and the amount of wind.

When using the temperature gauge in the hood of your barbecue please note that it measures air temperature. The air temperature inside your barbecue will never be as hot as the temperature of the cooking surface.

Roasting

For best results when roasting, the outer two burners should be used on the low to medium setting. Use of the high setting with the hood down may result in burnt food.

Remove the flat hotplate to help with heat circulation. Preheat the barbecue for a few minutes. Place a roasting rack or aluminium foil dish onto the ribbed hot plate and place the meal to be roasted onto the rack or into the dish and close the hood.

Adjust the control knob to maintain the temperature around the medium mark (approx. 200° to 230°C).

CARE & MAINTENANCE

As with all appliances, proper care and maintenance will keep them in top operating condition and prolong their life. Your new gas barbecue is no exception. By following these cleaning procedures on a timely basis, your barbecue will be kept clean and working properly with minimum effort.

Flash-Back

If fire occurs in and around the burner, immediately turn off gas at its source and turn the burner control to OFF, wait until the barbecue has cooled, then clean the burner tubes and burner ports as described in lighting and operating procedure.

Spiders and small insects occasionally spin webs or make nests in the burner tubes during warehousing and transit. These webs can lead to a gas flow obstruction which could result in a fire in and around the burner tubes. Cleaning with a soft brush before use and at least every six months is recommended.

This type of fire is known as 'FLASH-BACK' and can cause serious damage to your barbecue and create an unsafe operating condition for the user. Although an obstructed burner tube is not the only cause of 'FLASH-BACK' it is the most common cause and frequent inspection and cleaning of the burner tubes is necessary.

Cleaning the Cast Iron Cooking Surface

We recommend opening the hood and turning all burners on to high for 15 minutes to burn-off excessive food and avoid food build-up. For further cleaning, let barbecue cool, use a wire brush to remove remaining residue, then wash the grill plates in a mild soap and hot water. A mild cream cleaner with a non-abrasive pad can be used for more stubborn residue. Rinse well, dry thoroughly and apply a coat of cooking oil. Due to the weight of the grills, it is not recommended they are cleaned in a dishwasher. Do not use cleaners that contain acid, mineral spirits or xylene. If rust appears during storage, clean with a soft wire brush, wash in hot soapy water, dry, re-oil and cure.

Care of Cooking Surface

Use and care of the cooking surface is important. Do not use pans on the cooking surface. Do not overheat the cooking surface with the hood down or no food on the cooking surface.

Cleaning the Drip Tray

To avoid fat or grease dripping from the barbecue remove and empty the drip tray after each use. Wait until the drip tray is cool to touch before disposing of contents.

The drip tray should be washed periodically in a mild detergent and hot water solution.

Cleaning Plastic surfaces

Wash with warm soapy water and wipe dry. Do not use abrasive cleaners, degreasers or a concentrated appliance cleaner on plastic parts, as this can result in damage and/or failure of the parts.

Cleaning Porcelain surfaces

Because of glass-like composition, most residue can be wiped away with baking soda/water solution or specially formulated cleaner. Use nonabrasive scouring powder for stubborn stains.

Cleaning Painted surfaces

Wash with mild detergent or nonabrasive cleaner and warm soapy water. Wipe dry with a soft nonabrasive cloth.

Cleaning Stainless steel surfaces

To maintain your appliance's high quality appearance, wash with mild detergent and warm soapy water and wipe dry with a soft cloth after each use. Use only in direction of brushed finish to avoid damage.

Cleaning the Burner Assembly

1. Make sure the barbecue is cool.
2. Remove cooking grills, hotplate and flame tamers.
3. Remove the burner by taking off the R-clip from the rear end of the burner.
4. Lift the burner up and away from gas valve orifice.
5. Clean the inlet of burner with small bottle brush or compressed air.
6. Remove all food residue and dirt on the outside of the burner surface.
7. Clean any clogged ports with a piece of stiff wire (such as an opened paper clip).
8. Inspect the burner for any damage (cracks or holes). If damage is found, replace with a new burner. Reinstall the burner, check to ensure that gas valve orifices are correctly positioned inside burner inlet.
9. Overlap 15mm between tube and nozzle when assembled.
10. Keep the center line of tube and nozzle on one line.

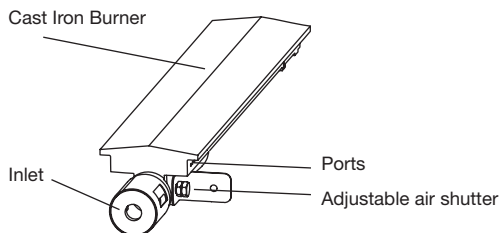

WARNING: If the instructions above are not followed, an explosion may result, possibly causing serious bodily injury or death

Adjust the Air Shutter

The adjustable air shutter controls the amount of air intake in the gas inlet. To adjust the air shutter.

1. Make sure the barbecue is cool.
2. Remove cooking grills, hotplate and flame tamers.
3. Access the burner that is not burning correctly.
4. Turn the adjustable air shutter clockwise to reduce the amount of air in the gas inlet, this will turn an orange flame into a cleaner burning blue flame.

DO NOT OVER CLEAN, AS THIS CAN CAUSE DAMAGE TO THE SURFACE OF THE METAL AND CAN VOID THE WARRANTY.

Storing the appliance

If the appliance needs to be stored for a prolonged period of time (e.g. over winter):

1. Set control knobs to off (red bar pointing upwards).
2. Close valve at the gas cylinder.
3. Remove the gas cylinder from the appliance, by unscrewing the gas hose.
4. Carefully clean the appliance.
5. The appliance can be stored in a dry location indoors (e.g. garage)
6. The gas cylinder needs to be stored outdoors in a dry and well-ventilated location and out of reach of children!
7. Cover the appliance.

When removing the appliance from storage check for burner obstructions.



IMPORTANT:

- Beware of spiders and wasps. Burner tube should be inspected and cleaned periodically.
- This appliance must only be serviced by an authorized person.
- To avoid any flare-ups, it is recommended that the drip tray be checked and emptied regularly. Contents of the drip tray may be very hot during cooking. If emptied during extended cooking extreme caution should be taken and direct contact by hand should be avoided at all times. Allow to cool completely before disposing of the contents.

SAFE APPLIANCE LOCATIONS

This appliance shall only be used in an above ground open-air situation with natural ventilation, without stagnant areas, where gas leakage and products of combustion are rapidly dispersed by wind and natural convection.

Any enclosure in which the appliance is used shall comply with the following:

An enclosure with walls on all sides, but at least one permanent opening at ground level and no overhead cover (see Example 1).

Within a partial enclosure that includes an overhead cover and no more than two walls (see Example 2 & 3).

Within a partial enclosure that includes an overhead cover and more than two walls, the following will apply: at least 25% of the total wall area is completely open, and at least 30% of the remaining wall area is open and unrestricted (see Example 4 & 5).

In the case of balconies, at least 20% of the total wall area shall be and remain open and unrestricted.

DIAGRAMMATIC REPRESENTATIONS OF OUTDOOR AREAS

The following figures are diagrammatic representations of outdoor areas. Rectangular areas have been used in these figures – the same principles apply to any other shaped area.

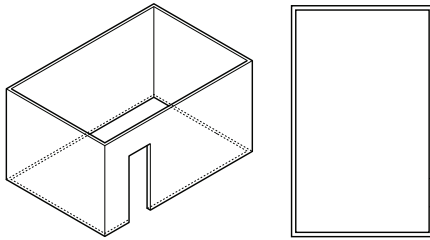

Outdoor Area - Example 1

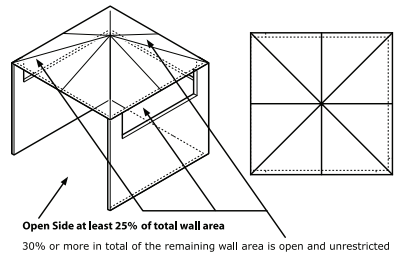

Open Side at least 25% of total wall area
30% or more in total of the remaining wall area is open and unrestricted

Outdoor Area - Example 4

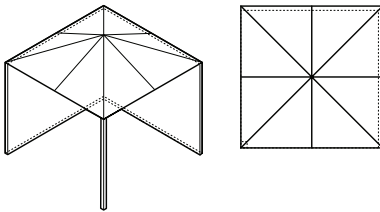

Outdoor Area - Example 2

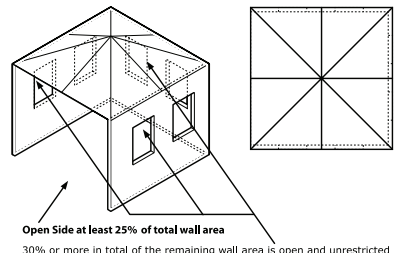

Open Side at least 25% of total wall area
30% or more in total of the remaining wall area is open and unrestricted

Outdoor Area - Example 5

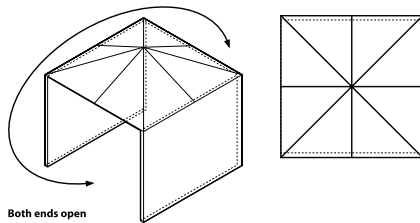

Both ends open

Outdoor Area - Example 3



2 YEAR LIMITED WARRANTY

Aber Living warrants the purchaser of this product against defects in workmanship and material, for a period of up to 24 months from the date of purchase. The warranty is non-transferable and becomes void if used for commercial or rental purposes.

Warranty and purchase receipt of this product are to be retained as proof of purchase and must be presented if making a claim under the terms of the Aber Living Warranty. Repairs under warranty are free of charge, provided the product is delivered to our Service Department or Authorised Service Agent and freight charges both ways are paid by the owner. No liability will be accepted for any loss of damage in transit.

Aber Living reserves the rights to replace or repair the product within the warranty period. Warranty does not apply to any defect, deterioration (including corrosion if located within 1km of the sea), loss, injury or damage occasioned by or as a result of the misuse or abuse, negligent handling or if the product has not been installed and used in accordance with the instructions. The warranty is void if there is evidence of the product being tampered with by unauthorised persons.

If the product includes one or a number of accessories, only the defective accessory or part will be replaced.

In the event of Aber Living choosing to replace the product, the warranty will expire at the original date, i.e. 24 months from the original purchase date.

Where this product contains information from an overseas country, nothing in that information is intended to limit any condition, guarantee, right or remedy which may be available under the Consumer Guarantees Act 1993, except to the extent permitted by that Act.

Approved for Outdoor Use Only.

For service, spare parts or product information in New Zealand, please call Aber Living on the Customer Service Line - 0800 161 161. www.aberliving.co.nz

YOUR PURCHASE RECORD (please complete)

Date of Purchase _____

Model Number _____

Serial Number (if applicable) _____

Purchased from _____