

Gasmate®

CATERER 4 & 6 BURNER BBQ



Model No. BQ1051

Model No. BQ1050

- Ideal heavy duty BBQ for sporting and social clubs or anywhere large groups are entertained
- Solid 5mm thick steel hotplate
- Castors for easy moving
- Stainless steel burners
- Removable lid that doubles as a windshield
- Foldable side shelves
- Universal L.P.G.
- Approved to New Zealand Standards

Important: Retain these instructions for future use.

CONTENTS

Section	Page
General Information	2-4
Parts List & Hardware List	5-6
Assembly Instructions	7-11
Care & Maintenance	12
Lighting Procedure	13
Burner Operation & Operating Procedure	14
Safe Appliance Locations	15

GENERAL INFORMATION

Gas Installation Codes

- Barbecues must be used in accordance with the New Zealand Standard 5601 "Gas Installations".
- Barbecues for use with bottled gas are labelled 'L.P.G'.
- Barbecues for use with natural gas are labelled 'natural gas' and must be installed by an authorised person. Check the gas type sticker attached to the barbecue.

Clearances

Minimum Clearances from combustible materials must be:

Rear - 300mm Sides - 300mm Above - 600mm

Hose & Regulator Safety

The regulator and hose assembly supplied with the barbecue are suitable for L.P.G only. A gas regulator adjusted to have an outlet pressure of 2.75kPA is supplied for connection to the LPG cylinder. The pressure regulator and hose assembly supplied with the barbecue must be used. Replacement pressure regulators and hose assemblies must be those specified by the barbecue manufacturer.

When connecting the hose and regulator assembly to the gas cylinder, take care to avoid unnecessary twisting of the flexible hose.

After the assembly has been secured, turn on the gas and check for leaks by brushing a soap and water solution over all connections.

If you are unable to correct the leak by tightening the connections, turn off the gas and contact the supplier immediately.

Always ensure the barbecue is kept away from flammable materials and the gas cylinder clear of any heat source.

When changing over from an empty gas cylinder to a full one make sure this procedure is carried out in a flame free atmosphere.

Specifications

Barbecue specifications can be found on the data label attached to the barbecue body.

Gas Cylinder Use & Safety

This is a low pressure barbecue and must only be used with the hose and regulator supplied. Your barbecue is designed for use with 9kg gas cylinders certified to AS 2469.

The gas cylinder should be filled by a reputable gas supplier and visually inspected and re-qualified at each filling.

Always keep cylinder in an upright position. Always close the cylinder valve when the barbecue is not in use.

Do not subject gas cylinder to excessive heat.

NEVER STORE YOUR GAS CYLINDER INDOORS.

If you store your barbecue indoors, ALWAYS disconnect the gas cylinder first and store the cylinder safely outside.

Cylinders must be stored outdoors in a well ventilated area out of reach of children, and must not be stored in a building, garage or any other enclosed area.

Location of your Barbecue

DO NOT use your barbecue in garages, porches, sheds, breezeways, or other enclosed areas. Your barbecue is to be used OUTDOORS. The barbecue is not intended to be installed in or on recreational vehicles and/or boats and should not be placed under any surface that will burn. Do not obstruct the flow of combustion and ventilation air around the barbecue housing.

Tools You Will Need

Standard Phillips-head screw driver (or cordless drill and bits) and Adjustable Spanner.

Check Barbecue for any Damage

Inspect barbecue parts as you proceed with assembly. Contact your supplier for assistance regarding replacement of any damaged or missing parts. Do not assemble or operate a barbecue that appears damaged. Barbecues for use with gas cylinders are labelled Universal L.P.G. Check labelling at the gas connection on your barbecue.

Protect Children

Keep children away from barbecue during use and until barbecue has cooled after you have finished.

Do not allow children to operate barbecue.

Always ensure that no sporting or physical activities are carried out in close proximity to the barbecue during use and while still hot.



FOR YOUR SAFETY

- Do not store or use petrol or other flammable liquids in the vicinity of this or any other appliance.
- Do not store empty or full spare gas cylinders under or near this or any other appliance.
- Keep the gas hose away from hot surfaces and protect from dripping grease. Avoid unnecessary twisting of hose. Visually inspect the hose prior to each use for cracks, excessive wear or other damage. Replace the hose if necessary.
- Never test for gas leaks with a lit match or open flame. Never light barbecue with hood closed or before checking to ensure the burner tubes are fully seated over gas valve orifices.
- Never lean over cooking surface when lighting.
- Never alter or modify the regulator or gas supply assembly.
- This barbecue must not be used indoors.
- Ensure the barbecue is set up on a level and stable surface.
- Do not move the barbecue while in use or when hot. Remove the drip tray before moving.



WARNINGS

- Failure to comply with these instructions could result in a fire or explosion which could cause serious bodily injury, death or property damage.
- Accessible parts may be very hot.
- Keep young children away.
- Any modifications to this barbecue may be dangerous.
- Do not move this barbecue during use.
- Turn off gas supply at the cylinder after use.
- Read instructions before using the barbecue.
- Parts sealed by the manufacturer or their agent must not be manipulated by the user.
- This barbecue is only to be used and stored outdoors.
- Never operate this barbecue without a regulator
- Do not test for gas leaks with an open flame
- If this information is not followed exactly, a fire causing death or serious injury may occur.
- Do not store a spare gas cylinder under or near this barbecue. Never fill the cylinder beyond 80% full. This barbecue is only to be used and stored outdoors.
- If you smell gas
 1. Shut off gas to the barbecue at its source, if possible.
 2. Extinguish any open flame.
 3. Open hood.
 4. If odour continues, immediately call your gas supplier or fire department.
- Do not connect your barbecue to a gas cylinder exceeding the 9kg capacity specified.
- Never connect an unregulated gas cylinder to your barbecue.
- Read carefully before assembling and operating your barbecue.

Overall Barbecue Dimensions

Including Side Shelves

Gas Type	Length	Width	Height
4 Burner	1428mm	579mm	956mm
6 Burner	1817mm	579mm	956mm

Nominal Hourly Gas Consumption

Model	Injector size	Total Gas Consumption	Gas Pressure	Gas Type
BQ1050	Ø 1.05 mm	56MJ/h	2.75 kPa	U.L.P.G.
BQ1051	Ø 1.05 mm	84MJ/h	2.75 kPa	U.L.P.G.

COMPONENTS - 4 BURNER

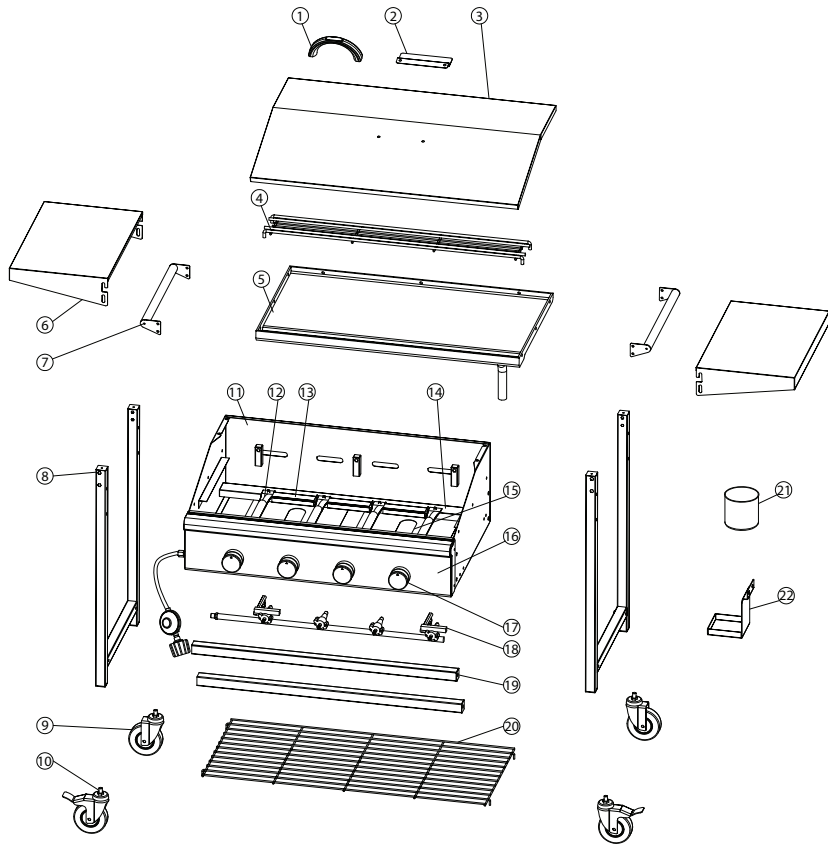

No.	Description	QTY
1	Lid Handle	1
2	Lid Hook	1
3	Lid	1
4	Warming Rack	1
5	Hotplate	1
6	Side Shelf	2
7	Side Handle	2
8	Leg Assembly	2
9	Castor without Brake	2
10	Castor with Brake	2
11	Firebox	1

No.	Description	QTY
12	Burner	4
13	Cross Igniter	3
14	Burner Support	1
15	Heat Shield	2
16	Control Panel Assembly	1
17	Knob	4
18	Manifold	1
19	Horizontal Tube	2
20	Bottom Rack	1
21	Grease Cup	1
22	Grease Cup Holder	1



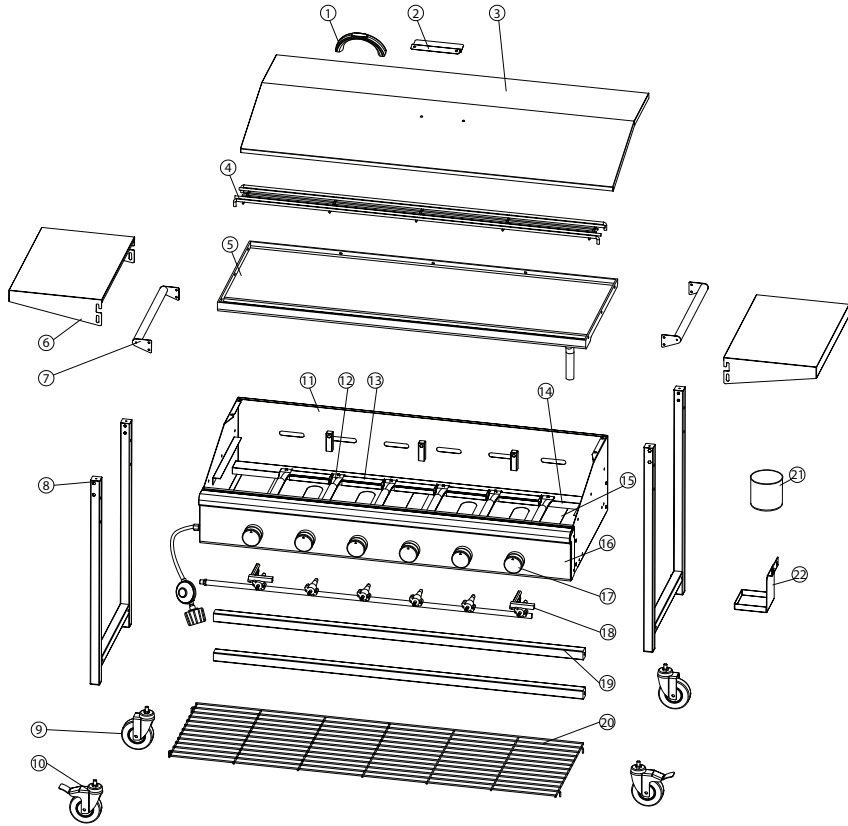

COMPONENTS - 6 BURNER



No.	Description	QTY
1	Lid Handle	1
2	Lid Hook	1
3	Lid	1
4	Warming Rack	1
5	Hotplate	1
6	Side Shelf	2
7	Side Handle	2
8	Leg Assembly	2
9	Castor without Brake	2
10	Castor with Brake	2
11	Firebox	1

No.	Description	QTY
12	Burner	6
13	Cross Igniter	5
14	Burner Support	1
15	Heat Shield	2
16	Control Panel Assembly	1
17	Knob	6
18	Manifold	1
19	Horizontal Tube	2
20	Bottom Rack	1
21	Grease Cup	1
22	Grease Cup Holder	1

HARDWARE

A  M6x40mm (x12)	B  M6x12mm (x4)	C  M5x12mm (x8)	D  M6 Shoulder Screws (x8)
---	--	--	--

IMPORTANT: Remove any transit protection material before use.

TOOLS: Phillips Head Screwdriver
Adjustable Spanner

ASSEMBLY INSTRUCTIONS

STEP 1

Attach the legs to the body using 8 x M6x40mm screws and the lower support beams using 4 x M6x40mm long screws. Screw the castors into the legs as shown.

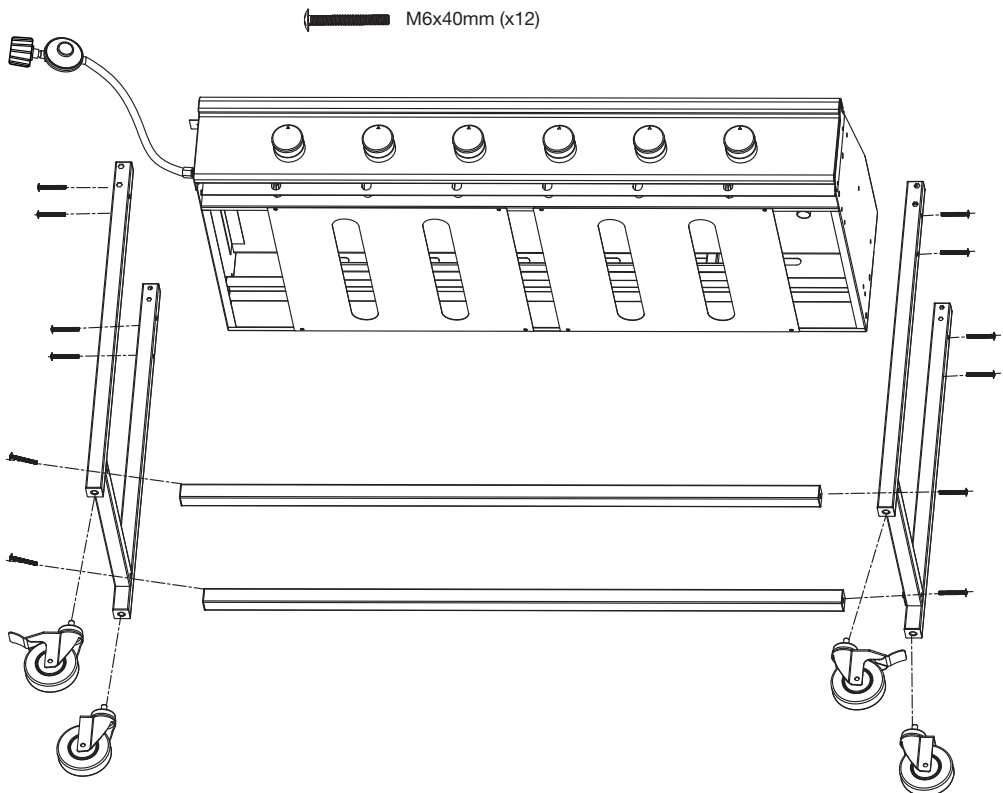

STEP 2

Attach the handles to the top of the legs using 8 x M5x12mm long screws, then attach fat cup holder as shown using 4 x M6x12mm long screws..

M6x12mm (x2)

M5x12mm (x8)

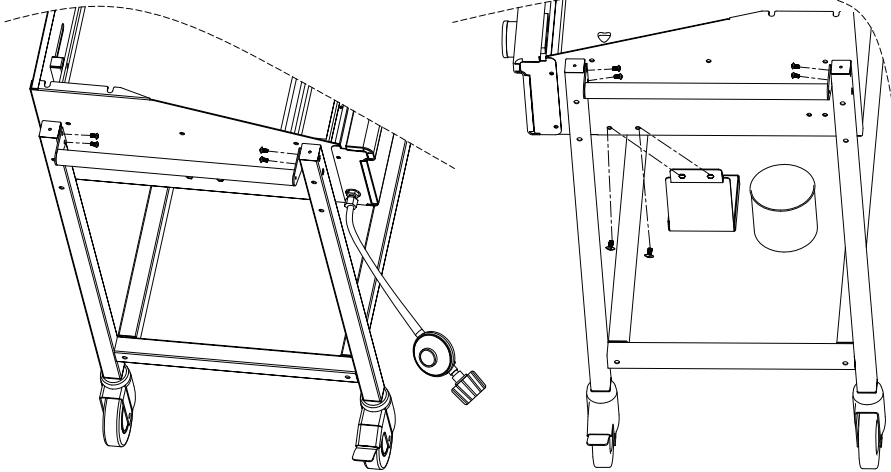

STEP 3

Attach the folding side shelves as shown using 8 x M6 shoulder screws.

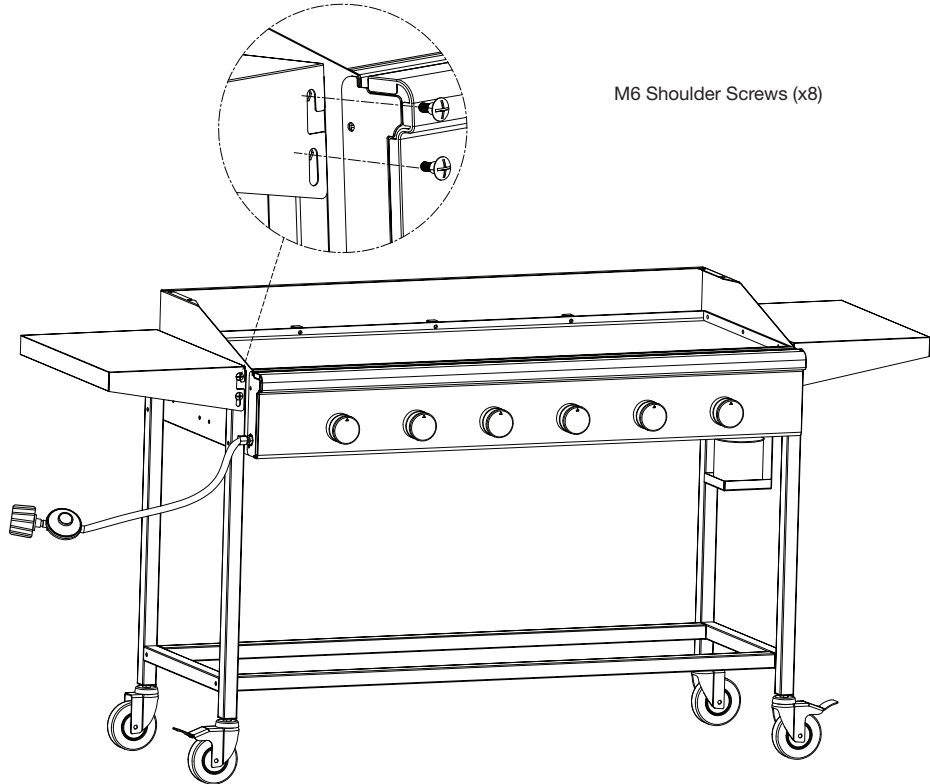

STEP 4

Attach the handle to the lid ensuring the lid hook is oriented as shown on the underside using 2 x M6x12mm screws. The lower wire rack and warming rack can be installed as required.

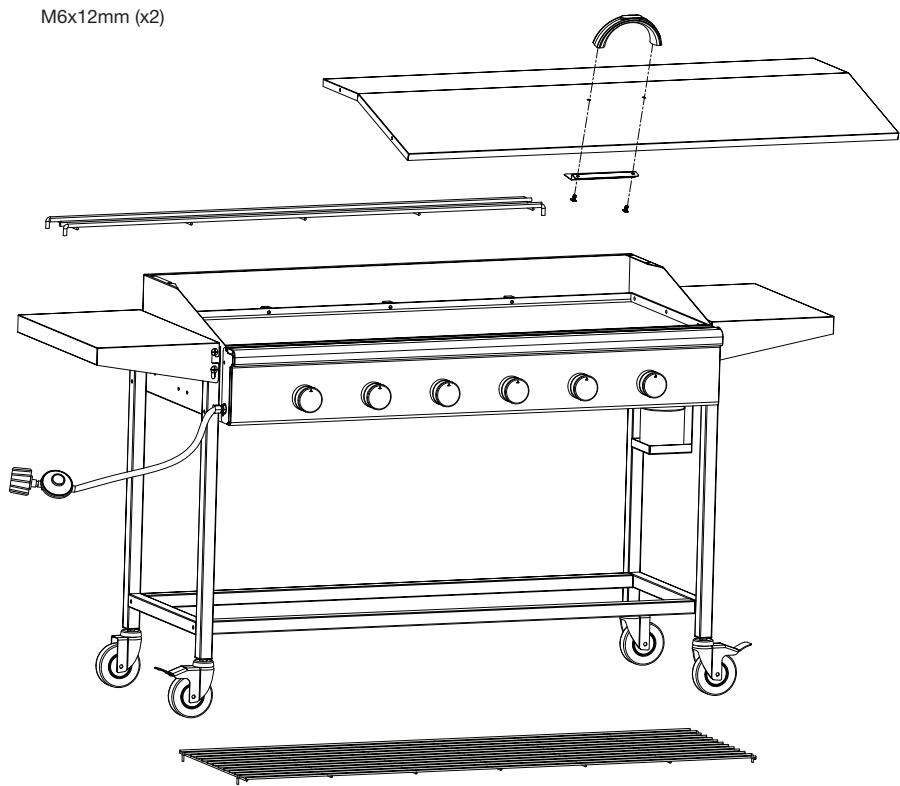

STEP 5

The completed assembly.

Note: Before use always leak test the connection to the gas cylinder using a soapy water solution.

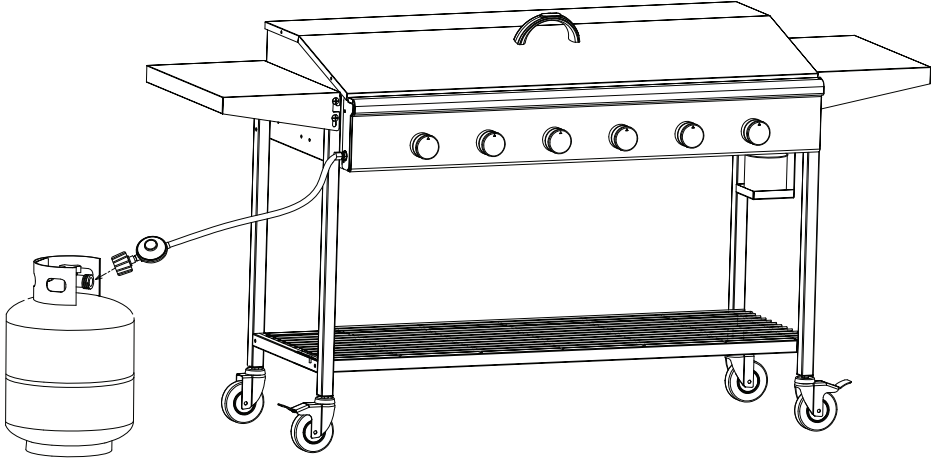

CARE & MAINTENANCE

Care & Maintenance

As with all appliances, proper care and maintenance will keep them in top operating condition and prolong their life. Your new gas barbecue is no exception. By following these cleaning procedures on a timely basis, your barbecue will be kept clean and working properly with minimum effort.

Flash-Back

Spiders and small insects occasionally spin webs or make nests in the burner tubes during warehousing and transit.

These webs can lead to a gas flow obstruction which could result in a fire in and around the burner tubes. This type of fire is known as 'FLASH-BACK' and can cause serious damage to your barbecue and create an unsafe operating condition for the user. Although an obstructed burner tube is not the only cause of 'FLASH-BACK' it is the most common cause and frequent inspection and cleaning of the burner tubes is necessary.

If fire occurs in and around the burner, immediately turn off gas at its source and turn the burner control to 'OFF', wait until the barbecue has cooled, then clean the burner tubes and burner ports.

Cleaning the Grill Plate

After cooking, turn burner control to 'OFF' and let barbecue cool before attempting to clean the grill plate. Before first use and periodically, it is suggested that you wash the grill plate in a mild soap and warm water solution.

Care of Cooking Surface

Do not use metal utensils or cut food on the cooking surface. Do not use pans on the cooking surface. Do not overheat the cooking surface with the hood down or no food on the cooking surface.

Service

If the appliance cannot be adjusted to perform correctly it should not be used until serviced or repaired.

GENERAL ASSEMBLY

Connecting & Disconnecting to Gas Source

Familiarise yourself with the general information and safety guidelines located at the front of this manual.

Check

1. Gas cylinder is filled. A sloshing sound will be heard when shaken.
2. The burner control is in the 'OFF' position

Connecting

1. Ensure cylinder valve is in its full 'OFF' position.
2. Check for any damage to either the cylinder connection or the hose. NEVER attempt to use damaged equipment.
3. When connecting the hose to the cylinder tighten the nut to a positive stop by hand or spanner.
4. Open cylinder valve fully. If a leak can be heard at either end of the hose, turn cylinder off and tighten joint. Wait 5 minutes before re-testing and use a soapy water solution to check the joint. If bubbles appear the connection will need to be re-tightened.

Disconnecting

1. Ensure the burner control is in the 'OFF' position.
2. Ensure gas cylinder is in the full 'OFF' position.
3. Detach the hose and regulator from cylinder.

REMOVING PROTECTIVE COATING

The hot plate has a food safe, protective coating which is applied to protect the hot plate from scratching during transport. This coating is designed to come off over time.

1. Put the burners on high for 20-30 minutes
2. Scrape off the coating with a metal scraper and a wire grill brush. Some areas may come off easier than other.
3. Season your barbecue

SEASONING YOUR BBQ

1. Clean hot plate with warm soapy water
2. Apply a layer of vegetable or cooking oil using a paper towel
3. Turn the burners on high and heat oil until light smoke appears
4. Turn off burners, let hotplate cool and wipe off any excess oil
5. Repeat process after every thorough clean of the hot plate

LIGHTING PROCEDURE

Burner Operation & Ignition System Check

1. With cylinder valve in 'OFF' position push and turn the far left or right control knob anti-clockwise to 'HIGH'. Check for sparking to the burners.
2. If spark is not evident at the burner ignition point, check for any loose leads at either the electrode or the ignition pack.
3. Push and turn anti-clockwise to 'HIGH' the far left or right control knob, subsequent burners will crosslight from right to left.
4. If the burner fails to light after several attempts, turn off the gas supply and inspect for any obstructions to the gas flow

If re-ignition is necessary while the gas barbecue is still hot, you must wait for a minimum of 5 minutes before commencing to re-ignite (this allows accumulated gas fumes to clear).

After Use

Turn the gas cylinder valve off and wait for the flame to go out. Then turn the appliance control valve off.



WARNINGS

- Before connecting and disconnecting barbecue to gas source, make sure burner controls are in 'OFF' position.
- Check that the seals between the appliance and the gas cylinder are in place and in good condition before connecting the gas cylinder.
- Do not use this appliance if it has damaged or worn seals.
- If for some reason, ignitor fails to produce a spark at the electrode, barbecue can be lit by a long barbecue match. With hood open, insert lighted match underneath control panel between the fascia and drip tray, alongside burner port on far right burner. Push and turn the far right control knob to 'HIGH'. Burner ignition can be checked through this gap. Subsequent burners will cross light.
- Check performance of burner prior to installing barbecue plates.
- Do not smoke when attempting to ignite barbecue.
- Never use volcanic rock, heat beads or other material.
- Always use protective gloves when handling hot components.
- Beware of spiders and wasps. Burner tube should be inspected and cleaned periodically.
- To avoid any flare-ups, it is recommended that the drip tray be checked and emptied regularly. Contents of the drip tray may be very hot during cooking. If emptied during extended cooking extreme caution should be taken and direct contact by hand should be avoided at all times. Allow to cool completely before disposing of the contents.
- When the barbecue is not in use, the gas must be turned off at the cylinder.
- The lid must be in the open position for lighting.
- Do not smoke at any time when attempting to ignite the barbecue burners.
- Do not leave the barbecue unattended when alight.

BURNER OPERATION & IGNITION SYSTEM CHECK

Problem	Possible Reason	Solution
Burner will not ignite	Valve on gas bottle closed	Open valve on gas bottle
	Control knob is closed	Turn knob to high when lighting
	Igniter is faulty	Use a long barbecue match. Insert through the hole at side of barbecue
Food is not cooking or is taking too long	Burner has gone out	Check that the gas bottle is not empty and re-ignite the burner
	Cooking surface was not given enough time to warm up before the food was applied	Remove the food and give the burner time to warm the cooking surface (5-10 minutes)
	There is too much food on the cooking surface	Cook smaller portions

NOTE: If the appliance cannot be adjusted to perform correctly it should not be used until serviced or repaired.

OPERATING PROCEDURE

Preheating

It is necessary to preheat the barbecue for at least 5 minutes before cooking certain foods, depending on the type of food and the cooking temperature. Food that requires a low cooking temperature, needs only a period of 2-3 minutes preheating.

Cooking Temperatures

'HIGH' setting - Use this setting only for fast warm up, for searing steaks and chops, and for burning food residue from the grill plates after cooking is over. Rarely, if ever, do you use the 'HIGH' setting for extended cooking.

'MEDIUM' setting (mid-way between 'HIGH' and 'LOW'). Use this setting for most grilling, and for cooking hamburgers and vegetables.

'LOW' setting - Use this setting when cooking very lean cuts such as fish.

These temperatures vary with outside temperature and the amount of wind.

SAFE APPLIANCE LOCATIONS

This appliance shall only be used in an above ground open-air situation with natural ventilation, without stagnant areas, where gas leakage and products of combustion are rapidly dispersed by wind and natural convection.

Any enclosure in which the appliance is used shall comply with the following:

An enclosure with walls on all sides, but at least one permanent opening at ground level and no overhead cover (see Example 1).

Within a partial enclosure that includes an overhead cover and no more than two walls (see Example 2 & 3).

Within a partial enclosure that includes an overhead cover and more than two walls, the following will apply: at least 25% of the total wall area is completely open, and at least 30% of the remaining wall area is open and unrestricted (see Example 4 & 5).

In the case of balconies, at least 20% of the total wall area shall be and remain open and unrestricted.

DIAGRAMMATIC REPRESENTATIONS OF OUTDOOR AREAS

The following figures are diagrammatic representations of outdoor areas. Rectangular areas have been used in these figures – the same principles apply to any other shaped area.

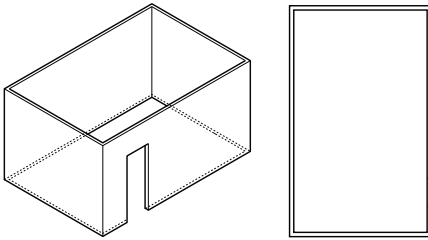

Outdoor Area - Example 1

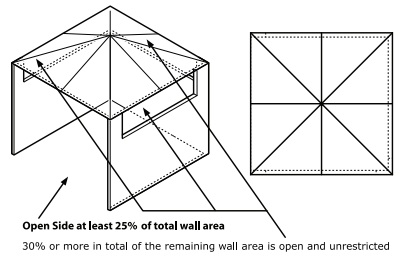

Outdoor Area - Example 4

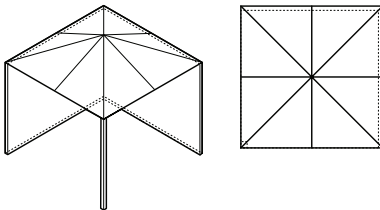

Outdoor Area - Example 2

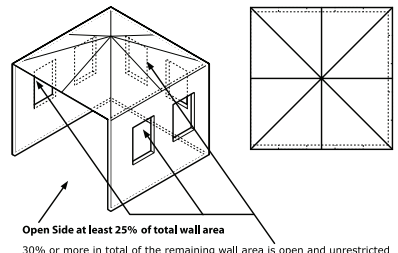

Outdoor Area - Example 5

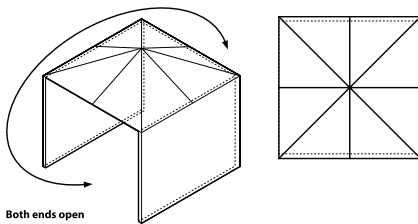

Outdoor Area - Example 3

BARBECUE RANGE

Aber Living warrants the purchaser of this product against defects in workmanship and material, for a period of up to 12 months from the date of purchase. The warranty is non-transferable and becomes void if used for commercial or rental purposes.

Warranty and purchase receipt of this product are to be retained as proof of purchase and must be presented if making a claim under the terms of the Aber Living Warranty. Repairs under warranty are free of charge, provided the product is delivered to our Service Department or Authorised Service Agent and freight charges both ways are paid by the owner. No liability will be accepted for any loss of damage in transit.

Note: In most cases the Barbecue Body only will need to be returned.

Aber Living reserves the rights to replace or repair the product within the warranty period. Warranty does not apply to any defect, deterioration (including corrosion if located within 1km of the sea), loss, injury or damage occasioned by or as a result of the misuse or abuse, negligent handling or if the product has not been installed and used in accordance with the instructions. The warranty is void if there is evidence of the product being tampered with by unauthorised persons.

If the product includes one or a number of accessories, only the defective accessory or part will be replaced, eg. hose, regulator, rotisserie, piezo igniter, roast hood, side burner and rail burners.

In the event of Aber Living choosing to replace the product, the warranty will expire at the original date, i.e. 12 months from the original purchase date.

Where this product contains information from an overseas country, nothing in that information is intended to limit any condition, guarantee, right or remedy which may be available under the Consumer Guarantees Act 1993, except to the extent permitted by that Act.

Approved for Outdoor Use Only

Fat fires are not covered under warranty

For service, spare parts or product information in New Zealand, please call Aber Living on the Customer Service Line - 0800 161 161. www.aberliving.co.nz

YOUR PURCHASE RECORD (please complete)

Date of Purchase ____ / ____ / ____

Model Number _____

Serial Number (if applicable) _____

Purchased from _____

Attach copy of purchase receipt here